

BEFORE YOU BEGIN

NOTE: The Storage Cart can be used to transport and store the guard rails and backdrop frames that are used with Wenger Versalite®, Trouper™, and Stagehand™, platform systems.

Remove all items from the shipping carton, and lay them out approximately in their final position. Refer to the assembled drawing below, and to the exploded drawings on the other side of the sheet.

TOOLS REQUIRED

- Two 1/2" open-end or socket wrenches:

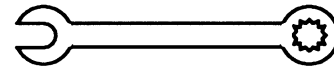

FASTENERS USED FOR ASSEMBLY

- ⑦ Lock Nut:



- ⑫ Carriage Bolt:

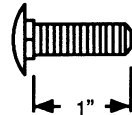

- ⑧ Carriage Bolt:

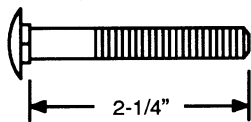

- ⑮ Flat Washer:



- ⑨ Capscrew:

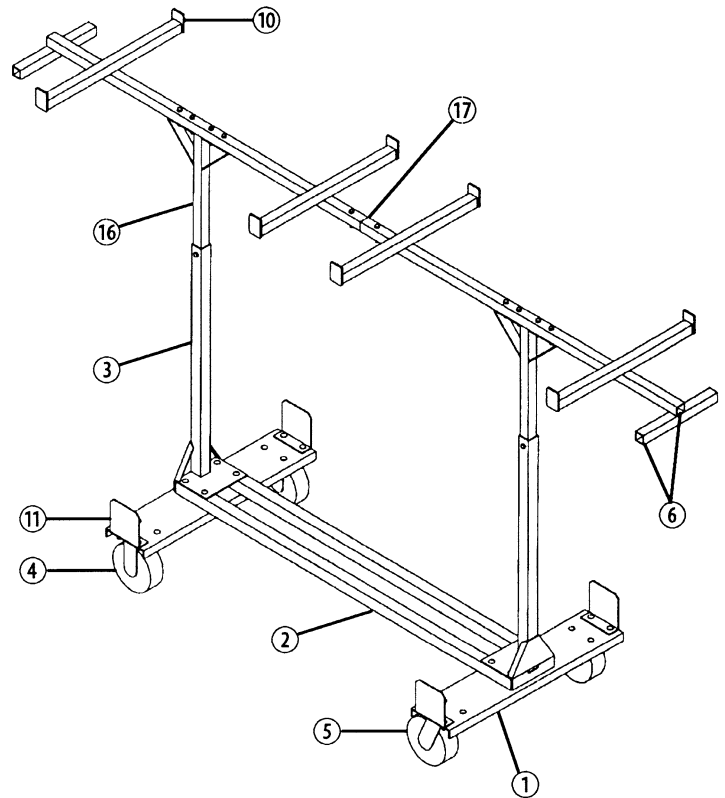
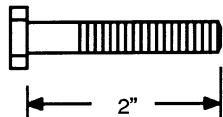

REPLACEMENT PARTS

Item	Description	Qty.	Item	Description	Qty.
1	Channel, caster	2	9	Capscrew, 5/16-18 x 2"	12
2	Brace, center	2	10	Rack Assembly	2
3	Upright Weldment	2	11	Bracket, stabilizer	4
4	Caster, swivel	2	12	Bolt, carriage, 5/16-18	16
5	Caster, rigid	2	15	Washer, flat, 1/4" I.D.	16
6	Plug, 1-1/4" square	6	16	Tube Weldment, upright	2
7	Nut, lock, 5/16-18	36	17	Tube, insert	1
8	Bolt, carriage, rd-head, 5/16-18	8			

ASSEMBLY

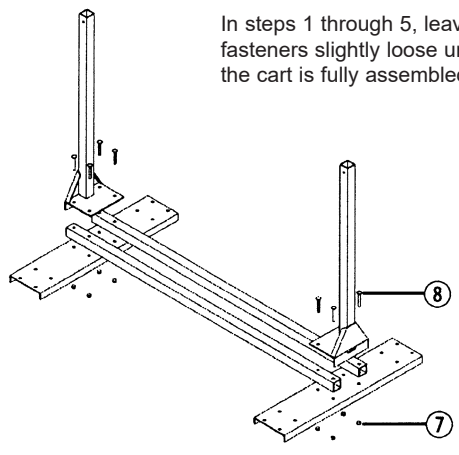
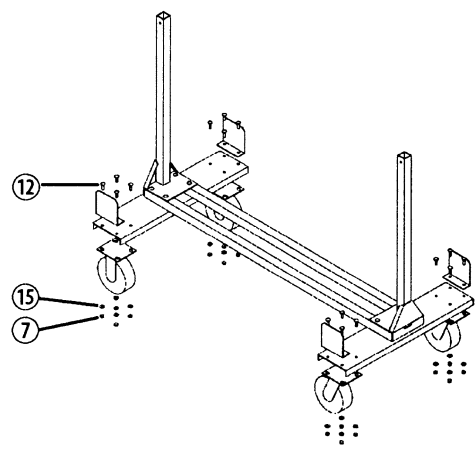
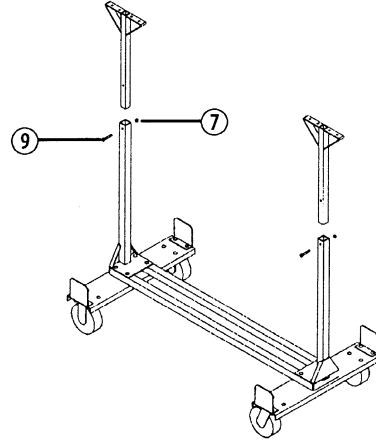
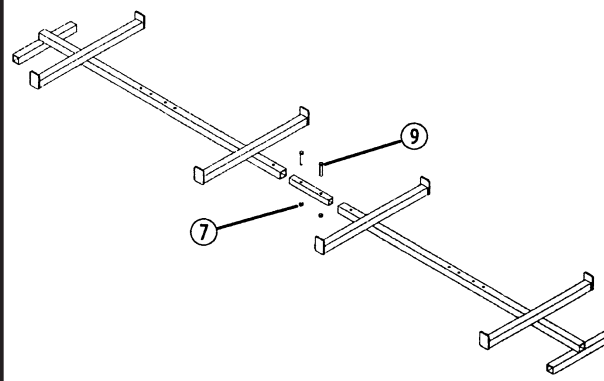
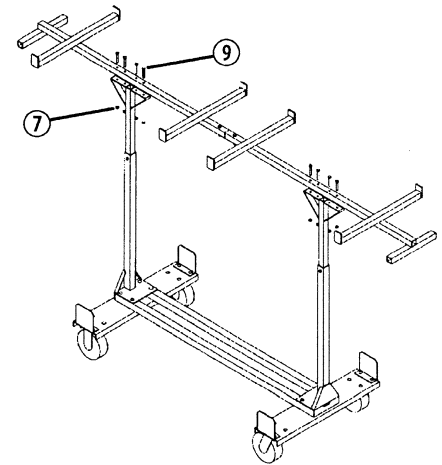
 <p>In steps 1 through 5, leave all fasteners slightly loose until the cart is fully assembled.</p> <p>1. Assemble the uprights (3), center brace (2), and caster channels (1).</p>	 <p>2. Attach swivel casters (4) at one end of the cart, rigid casters (5) at the other end.</p>
 <p>3. Attach the upright support tubes (16).</p>	 <p>4. Assemble the rail rack, using two rack assemblies (10) and the insert tube (17).</p>
 <p>5. Attach the rail rack to the cart.</p>	<p>6. Tighten all fasteners securely.</p>